



Ottawa Hull K1A 0C9

(21)	(A1)	2,156,036
(22)		1995/08/14
(43)		1996/02/25

(51) Int.Cl. ⁶ G01B 5/02; G03B 41/00

(19) (CA) **APPLICATION FOR CANADIAN PATENT** (12)

(54) Calculating Graphic Scaler

(72) Ferris, Byron S. - U.S.A. ;
Weeks, Loren T. - U.S.A. ;

(71) Same as inventor

(30) (US) 08/296,221 1994/08/24

(57) 19 Claims

Notice: This application is as filed and may therefore contain an incomplete specification.



2156036

Abstract of the Disclosure

A crop, measure and scale system and a measure and scale system are provided for use in preparing an original image for processing. The crop, measure, and scale system includes first and second corner members which define an adjustable image frame. Each corner member includes a pair of diverging arms, one arm being characterized as an abscissa arm and the other as an ordinate arm, each of which includes an internally facing edge. A calculating measure is mounted on one of the corner members, such calculating measure including a slide rule with a ruler which extends between opposite edges of the cropped image, and a slide which provides for calculation of a reduction/enlargement percentage based on a predetermined desired dimensional change. The measure and scale system includes the calculating measure described above joined to an elongate member.

2156036

CALCULATING GRAPHIC SCALER

Technical Field

The present invention relates generally to the preparation of graphic images for processing, and more particularly, to a system whereby images are visually cropped, measured and scaled or in some instances just measured and scaled. The two practices are accomplished, on the one hand, via a device which employs a pair of relatively adjustable corner members, at least one of which includes an onboard calculating slide rule, or, on the other hand, via a related device which includes a pair of relatively moving members which bear markings enabling both measurement and calculating logarithmic scaling. Although
10 the invention has broad utility, it is described below for use in a graphic arts environment, a context in which particular utility has been shown.

Background Art

Until now, graphic artists and designers have prepared images for processing using a variety of separate, single-function tools. Visual cropping, for example, has been accomplished by placement of a plurality of rulers (or other straight edge devices) on an image so as to obscure portions of the image from view. This procedure has required careful alignment of the image on a table, and of the rulers on the image so as to ensure that the visually cropped image will be "square". Measuring the dimensions of the cropped image also has required careful alignment of the rulers, such dimensions generally being
20 taken by measuring the distance between a pair of rulers which define opposite borders of a cropped image therebelow. The rulers must be held in position simultaneously, adding further to the difficulty of the task.

After the image has been visually cropped and measured, it has been conventional to calculate a reduction/enlargement percentage, such percentage corresponding to a desired change in the image's size. The calculation of such reduction/enlargement percentage previously has been accomplished using a "proportion wheel", a device which is manipulatable to identify the reduction/enlargement percentage

by setting a measured dimension and a corresponding desired dimension on the wheel. In a somewhat related practice which does not involve cropping, but rather just measuring and scaling, a linear ruler has been used for the measuring activity and thereafter, the same kind of scaling wheel just mentioned has been used for the calculating activity. In both prior art practices therefore, the designer must manipulate two tools to accomplish the desired end results.

It would be desirable to provide a system which does not require the manipulation of a variety of different tools. It is therefore an object of this invention to provide a system which, where cropping is desired, allows such to be accomplished easily
10 visually without requiring precise alignment of rulers, and with respect to scaling, enables the same without necessitating the use of a separate calculating device.

Summary of the Invention

The aforementioned objects are addressed by provision of two similar systems, one of which is a crop, measure and scale system and the other of which is a measure and scale system. Both systems are for use in preparing an image for processing. The crop, measure and scale system includes a pair of interrelated members which move relatively to define an adjustable cropped image frame. The members preferably take the form of a pair of L-shaped corners, or corner members, the corner members coming together to define a size-adjustable rectangular frame. Each corner member includes a pair of edges, each edge
20 being defined as either an abscissa or an ordinate edge. The abscissa edges define upper and lower borders of a cropped image, and the ordinate edges define opposite side borders so as to complete the image frame. The image height and width are measured by fixed rulers which extend along the edges of one of the corner members, one ruler being arranged to indicate positively the distance between facing abscissa edges, and the other ruler being arranged to indicate positively the distance between facing ordinate edges. A calculating measure is mounted on one of the corner members, such measure including a slide rule which employs one of the rulers as the slide rule's ruler, and a sliding logarithmic scale as

the slide rule's slide. The slide rule's ruler includes a translator which converts a dimensional measurement to a logarithmic scale. The slide rule's slide includes related logarithmic reduction percentage, and enlargement percentage scales. This arrangement provides for calculation of a reduction/enlargement percentage based on a desired dimensional change of the cropped image's size. The measure and scale system includes the calculating measure described above on an elongate member. The measure and scale system provides a single tool that can be used both to measure an image and to calculate a reduction/enlargement percentage based on the desired dimensional change of the image's size.

10

Brief Description of the Drawings

The preferred embodiment of the measure and scale system is simply a subset of the preferred embodiment of the crop, measure and scale system. Thus, to economize space, a single set of drawings is used to illustrate both the preferred embodiment of the crop, measure and scale system and the preferred embodiment of the measure and scale system. The reader is asked to first view the figures as illustrations of the preferred embodiment of the crop, measure and scale system, then the reader is asked to re-view the figures and focus only on those elements which illustrate an embodiment of the measure and scale system. Figs. 1, 1A, 2 and 2A serve the dual functionality illustration task just mentioned.

20

Fig. 1 (first functionality) is a somewhat simplified top plan view of a crop, measure and scale system constructed in accordance with the present invention, the system including a pair of interrelated corner members with an onboard calculating measure arranged to frame a cropped image which is 6-inches wide by 5-inches high. In its second functionality role, to be explained more fully below, Fig. 1 illustrates the proposed measure and scale system.

Fig. 1A (first functionality) is an enlarged fragmentary top plan view of the crop, measure and scale system shown in Fig. 1, the view illustrating operation of such

system where the image's width is to be reduced. Fig. 1A's second functionality role will become clear in the appropriate description below.

Fig. 2 (first functionality) shows the crop, measure and scale system of Fig. 1 wherein the corner members have been moved relative to one another to frame a cropped image which is 3-inches wide by 3-inches high. The Fig. 2 second functionality role tracks below with the Fig. 1 second functionality role.

Fig. 2A (first functionality) is an enlarged fragmentary top plan view of the system in the arrangement shown in Fig. 2, the view illustrating operation of such system where the image's width is to be enlarged. Second functionality performance of this figure follows that of the Fig. 2 second functionality.

Fig. 3 is a partially exploded isometric view of the preferred embodiment of the crop, measure and scale system as viewed from below.

Fig. 4 is a fragmentary, enlarged isometric view illustrating a track and carriage arrangement whereby the corner members are interrelated.

Fig. 5 is a further enlarged sectional view taken generally along line 5-5 of Fig. 1.

Fig. 6 is a sectional view, on about the same scale as Fig. 5, taken generally along line 6-6 of Fig. 1.

Detailed Description of Preferred Embodiments
of, and Best Mode of Carrying Out, the Invention

1. Crop, Measure and Scale System

As previously indicated, the present invention relates generally to the preparation of a graphic image for processing, and more particularly, to a calculating graphic scaler in the form of a system which provides for visual cropping of the image, measurement of a cropped image's dimensions, and determination of a reduction/enlargement percentage which corresponds to a desired change in image size. A preferred embodiment of such system is depicted in the drawings, the system being indicated generally at 10.

Referring initially to Fig. 1, it is to be noted that crop, measure and scale system 10 includes a pair of facing, interrelated corner members 12, 14, such corner members being relatively movable so as to define an adjustable image frame. The frame in turn defines a cropped image 16. The corner members preferably take the form of facing right angles (90° angles), each of which is defined by a pair of diverging arms. One of the corner members includes a calculating slide rule 18. The arms are characterized as abscissa and ordinate arms, such arms corresponding to X and Y coordinates of a graph in the plane of the drawing sheets as viewed in Figs. 1 and 2. As indicated, corner members 12 and 14 are interrelated, the ordinate arm of member 14 intersecting the abscissa arm of member 12, and the abscissa arm of member 14 intersecting the ordinate arm of member 12. The corner members thus define an image frame which in turn defines the borders (or perimeter) of the image framed thereby. Member 12 acts as a base relative to which member 14 is moved, such relative movement providing for adjustment of the frame size. This is illustrated by X-axis arrow 28 and Y-axis arrow 30, member 14 being readily movable either in the X or Y direction so as to vary the size of the frame. Such relative movement is further illustrated by comparison of Figs. 1 and 2.

In accordance with the preferred embodiment first corner member 12 will be understood to include a first abscissa arm 20 and a first ordinate arm 22. Arm 20 in turn defines a first abscissa edge 20a and edge 20a defines a first abscissa border of cropped image 16. Arm 22 defines an ordinate edge 22a and correspondingly a first ordinate border of cropped image 16. The first corner member thus may be considered to define a first perimeter extent of the image which is framed.

Similarly, second corner member 14 defines a second abscissa arm 24 and a second ordinate arm 26. Arm 24 defines a second abscissa edge 24a and arm 26 defines a second ordinate edge 26a, each edge defining a corresponding border of cropped image 16. These borders collectively make up a second perimeter extent of the image which is framed.

Focussing for a moment on the perimeter defined by the system, it will be appreciated that such system frames what may be considered a visually cropped image by placement of the system on an original image so as partially to cover the image with corner members 12 and 14. As shown, the resulting visually cropped image is generally rectangular, and is dimensioned to have a width W and a height H . In Fig. 1, the frame is 6-inches wide by 5-inches high. These dimensions are indicated by rulers along the abscissa and ordinate arms of corner member 12. The frame dimensions, however, may be altered by relative movement of the corner members as indicated by arrows 28 and 30.

10 In Fig. 2, the corner members have been moved relative to one another, so as to define a smaller visually cropped image 16'. Image 16' will be seen to have a height H' of 3-inches and a width W' of 3-inches. It is to be noted that movement is such that the rectangularity of the visually cropped image is maintained. A description of the mechanism by which such controlled movement is achieved is described in detail below.

Fig. 3 shows an exploded isometric view of the invented system, such view further illustrating the relationship between the first and second corner members and the controlled relative movement thereof. First corner member 12 includes a pair of corresponding sections 12a, 12b which come together to define slots (20b in Fig. 5; 22b in Fig. 6) through which the second corner member 14 is controllably passed. The sections are secured together via suitable fasteners which take the form of a pin and socket arrangement
20 in the embodiment shown. As indicated by arrows 28, 30 (Figs. 1 and 2), the arms of the second corner member are movable through the slots, but only in directions which are perpendicular to the first corner member's corresponding arms. This makes for a system whereby the width and height of a visually cropped image may be altered while maintaining the rectangularity nature of the frame.

Referring still to Fig. 3, it will be noted that abscissa arm 20 of the invented system provides a track 32, such track accommodating controlled movement of member 14 relative to member 12. As indicated, track 32 is defined along arm 20 which is combined

with a track-defining plank 32a. Plank 32a is secured to a projecting pedestal 32c of arm 20, providing a pair of grooves 32b. A carriage 34 rides along the track and is held on the track by a pair of shoes 34a which ride in grooves 32a to grip the plank in a manner illustrated in Figs. 5 and 6.

Turning to Fig. 4, it will be noted that the carriage defines a channel 34b through which arm 26 of corner member 14 is slidably received. This allows for controlled movement of corner member 14 either perpendicular or parallel to the system's first abscissa arm 20. The second corner member's ordinate arm 26 thus is captured between shoes 34a and a plurality of channel-defining underlying bars. Fig. 4 further illustrates the sliding relationship between the first and second corner members, such relationship being illustrated by arrows 28 and 30 from Fig. 1. Tabs 34c, ensure a well-defined, but low-resistance, path of second corner member 14. This arrangement is also illustrated in Fig. 5, it being made apparent that shoes 34a capture plank 32a for sliding passage of the carriage therealong. The track-defining plank 32a, it will be recalled is secured to abscissa arm 20, providing for a controlled relationship between carriage 34 and arm 20. Fig. 5 also provides a view of slot 20b, through which arm 26 is slidably passed.

Fig. 6 shows, in cross-section, the relationship between the second corner member's abscissa arm 24 and the first corner member's ordinate arm 22, it being clear that the track and carriage arrangement is not necessary at both intersections of the first and second corner members. As indicated, the arm 24 passes through a channel 22b formed in arm 22, the channel being defined by the upper and lower sections 12a, 12b of corner member 12.

Once an image has been visually cropped, the image may be marked with lines designating the cropped image using a felt pen or the like. Such markings may be made, for example, through slots (or apertures) in the corner members such as those shown at 36. The slots extend entirely through each corner member and are intended for marking at opposite corners of the image where the image is rectangular. Additional marking slots may

be provided in the arms of the corner members, representative examples of such slots being indicated generally at 38. These slots provide for marking along a side edge of the image.

Once the image has been visually cropped, attention shifts to the calculating measure 18 which, in the preferred embodiment, is mounted along abscissa arm 20 of corner member 12. As indicated, the calculating measure takes the form of a slide rule, such slide rule including of a stationary ruler 18a and a movable slide element 18b. The stationary ruler is configured to allow for measurement of the image's width W, such ruler extending along the system's first abscissa edge 20a. A similar ruler 17 (Fig. 2A) extends along the system's first ordinate edge 22a so as to provide for measurement of the image height H.

10 As suggested by arrow 19, the slide rule's slide 18b is movable relative the slide rule's ruler 18a along the length of the slide rule ruler, such movement generally being undertaken so as to calculate a reduction/enlargement percentage based on a desired change in visually cropped image size as will now be described.

Referring now to Fig. 1A, determining the percentage of reduction of an image such as image 16 is provided, the system's calculating measure being shown in detail. As indicated, the image has been chosen to have a width W of 6-inches, such width being read from a linear scale 40 which appears on ruler 18a along the edge of the first corner member's abscissa arm. The ruler, it will be recalled, is fixed to the first abscissa arm. As also indicated, the stationary ruler 18a includes a first logarithmic conversion scale 42 which
20 is positioned to extend adjacent (and parallel) slide rule slide 18b. The logarithmic scale is associated with the linear scale as by lines such as that shown at 40a. This association effectively converts a linear measurement to the logarithmic scale. The stationary ruler thus acts as a translator and is referred to as such herein. Consequently, the measured width W is readily represented on the logarithmic scale 42 for further manipulation by the slide rule's slide.

Referring more specifically now to the system's slide, it will be noted that such slide includes a second logarithmic scale 44, such scale being positioned adjacent the first

logarithmic scale to provide for manipulation of the calculating measure to denote a predetermined desired dimensional change in the image's width. Those skilled will appreciate, for example, that the second logarithmic scale 44 has been moved, in Fig. 1A, to denote a reduction from a width of 6-inches to a width of 4½-inches, the second logarithmic scale being arranged to indicate a predetermined desired image width. The second logarithmic scale thus has been offset relative the first logarithmic scale to indicate a width 4 ½-inches where the first logarithmic scale indicates a width of 6-inches. It should also be noted that, although the current description refers the image width W, calculations may similarly be made regarding the image height by reference to values corresponding to the measured height H on the linear and logarithmic scales.

10

As shown, the slide is contained within a groove in the first abscissa arm, and is partially covered by a shield (47 in Fig. 5) so as to obscure additional scales marked thereon. In Fig. 1A, one of these additional scales is shown at 46, such scale taking the form of a reduction percentage scale. Scale 46 represents a percentage of reduction which corresponds to the relative offset of the first and second logarithmic scales. The reduction percentage scale appears only partially through a window 46a in the shield 47, the corresponding percentage of reduction being indicated by a pointer, or marker 46b.

In the depicted arrangement of Figs. 1 and 1A, where the width measurement is to be changed from 6-inches to 4½-inches, it will be appreciated that the image will be reduced to 75% of its original size. By appropriate relative placement of the first and second logarithmic scales in the fashion indicated, it therefore is possible to provide for simultaneous indication of a linear dimension reduction.

20

Turning now to Fig. 2A, and by similar analysis, it will be noted that the enlargement percentage of image 16' similarly may be determined by manipulation of slide 18b, and by reading of an enlargement percentage scale 48 which is seen through a second window 48a. A pointer (or marker) 48b, indicates the enlargement percentage directly. The

second window is offset both vertically and horizontally (as viewed in Fig. 2A) from the first window, avoiding overlap of the scales.

As indicated in Fig. 2A, cropped image 16' has a width of 3-inches which is to be enlarged to approximately 3 ¾-inches. This enlargement will be understood by reference to the relationship between the first and second logarithmic scales, such scales being offset so that the second logarithmic scale indicates a width of 3¾-inches where the first logarithmic scale indicates a width of 3-inches. Correspondingly, pointer 48h indicates an enlargement percentage of 125%. The slide is moved by hand, and may further include a tab 50 as a finger hold.

10 Those skilled will appreciate that use of English dimensional units (i.e., inches) is illustrative only, and that other units of measure obviously easily could be employed.

2. Measure and Scale System

As has been set forth in the Background and Summary of this invention, and as was explained with reference to the descriptions of Figs. 1, 1A, 2 and 2A in the drawings, there are two slightly different embodiments of this invention. The characteristics of which are illustrated by taking slightly different view points of and readings with respect to the interpretations of these four drawing figures. In the description which now follows of the preferred embodiment of the measure and scale system, the reader is asked to focus attention on certain portions only of the structures illustrated in Figs. 1, 1A, 2 and 2A with
20 the view toward eliminating from consideration, in a manner of thinking, certain structural components which do not play any role in the construction and functionality of the embodiment of the invention now to be described. Elements of this now-to-be-described embodiment of the invention which are common, in the sense, with like elements in the first-above-described embodiment bear the same reference numerals.

A preferred embodiment of the measure and scale system is shown in Figs. 1 and 2 as the abscissa arm of corner member 12 together with the calculating measure within and upon the abscissa arm. This embodiment can be visualized by focussing on the

abscissa of corner member 12 and ignoring the ordinate of corner member 12 and the whole of corner member 14. Thus, it can be seen that the measure and scale system includes a ruler 18a along an elongate edge 20a, and a calculating slide rule 18. The ruler and calculating slide rule are part of a calculating measure which is shown in detail in Figs. 1A and 2A. These figures illustrate how the calculating measure can be used to calculate either a reduction percentage for an image, Fig. 1A, or an enlargement percentage for an image, Fig. 2A. Only the elements in Fig. 1A and 2A that are part of the calculating measure or part of the abscissa of corner member 12 are elements of the measure and scale system. Thus elements 14, 17 and 36 are not part of the measure and scale system. Figs. 1A and 10 2A were discussed previously in describing the calculating measure used in the crop and measure system. Since the calculating measure used in the measure and scale system is identical to that used in the crop, measure and scale system, the reader is referred to the previous discussion of Figs. 1A and 2A for a detailed description of the calculating measure.

It should thus be apparent how the preferred embodiments of this invention -- which direct their respective attentions to two different aspects of graphics "manipulation" -- i.e. crop, measure and scale, and measure and scale, respectively, offer distinct advantages in the practice of these activities in relation to prior art practices utilizing prior available tools in the trade so-to-speak. Put succinctly, the embodiments of the present invention, with regard to their respective practice arenas, enable the desired steps and stages of 20 graphic manipulation to be performed by using but a single tool into which are integrated all of the elements necessary to perform the respective required steps. By using a structure made in accordance with the present invention, no longer is it necessary for a user to possess and reach for two very different kinds of tools to perform two very different kinds of functions. In both embodiments, one can say in a very simple manner of speaking that one tool does it all.

It should also be apparent to those skilled in the art that the proposed embodiments of the present invention are relatively simple and inexpensive to manufacture,

and require no substantial re-education, or "new-technology" adaptation for their successful and convenient use.

Although preferred embodiments of the inventions have been disclosed, it should be appreciated that variations and modification may be made thereto without departing from the spirit of the inventions as claimed.

The embodiments of the invention in which an exclusive property or privilege is claimed are defined as follows:

1. A measure and scale system for use in preparing an original image for processing, the system comprising an onboard, elongate measure which includes a stationary ruler and an adjacent slide wherein the adjacent slide is manipulatable to designate a predetermined desired dimensional change in the original image, such a manipulation resulting in the identification of a value representing a corresponding percentage change.

2. A crop, measure and scale system for use in preparing an original image for processing, the system including an adjustable image frame, the system comprising a first member including an elongate first edge suited for placement adjacent the original image to define a first cropped image border; a second member operatively connected to said first member and including an elongate second edge which is movable relative to said first edge to define a second cropped image border opposite the first cropped image border; and an onboard, elongate measure which extends between said first and second edges to indicate a distance therebetween.

3. The crop, measure and scale system of claim 2, wherein said measure is a slide rule which includes a stationary ruler and an adjacent slide.

4. The crop, measure and scale system of claim 3, wherein said slide rule is manipulatable to designate a predetermined desired dimensional change in the original image, such manipulation resulting in the identification of a value representing a corresponding percentage change.

5. The crop, measure and scale system of claim 3, wherein said slide rule ruler includes a translator having both a linear scale and a logarithmic conversion scale, said logarithmic conversion scale being aligned with said linear scale to provide for translation of said distance from said linear scale to said logarithmic conversion scale.

6. The crop, measure and scale system of claim 5, wherein said slide rule's slide includes a logarithmic reduction/enlargement scale which at least partially mirrors said logarithmic conversion scale, said slide being movable relative to said ruler to offset said logarithmic reduction/enlargement scale from said logarithmic conversion scale to denote a predetermined desired dimensional change in said distance.

7. The crop, measure and scale system of claim 6, wherein said slide rule further includes a reduction percentage scale and a reduction marker, one of which is fixed relative to said logarithmic conversion scale and another of which is fixed relative to said logarithmic reduction/enlargement scale, said reduction percentage scale being arranged to provide for marking by said reduction marker of a reduction percentage value corresponding to the relative offset of said logarithmic scales.

8. The crop, measure and scale system of claim 6, wherein said slide rule further includes an enlargement percentage scale and an enlargement marker, one of which is fixed relative to said logarithmic conversion scale and another of which is fixed relative to said logarithmic reduction/enlargement scale, said enlargement percentage scale being arranged to provide for marking by said enlargement marker of an enlargement percentage corresponding to the relative offset of said logarithmic scales.

9. The crop, measure and scale system of claim 2, wherein said first member further includes a track which extends generally perpendicularly from said first edge, said second member being mounted for movement both along said track and generally perpendicularly to said track.

10. A crop, measure and scale system for use in preparing an original image for processing, the system including an adjustable image frame which defines a perimeter of a cropped image, said system comprising a first corner member including a first abscissa edge and a first ordinate edge, said first corner member being suited for placement on the original image to define a first perimeter extent of the cropped image; a second corner member operatively connected to said first corner member, said second corner member including a second abscissa edge which opposes said first abscissa edge and a second ordinate edge which opposes said first ordinate edge, said second corner member being controllably movable relative to said first corner member to define a second perimeter extent of the cropped image; and a calculating measure mounted on one of said corner members (1) to indicate a distance between selected opposing edges of the corner members, (2) to indicate a desired dimensional change of said distance, and (3) to indicate a desired percentage change which corresponds to said desired dimensional change of said distance.

11. The crop, measure and scale system of claim 10, wherein said first and second corner members define 90° angles.

12. The crop, measure and scale system of claim 11, wherein said first corner member intersects with said second corner member to define a rectangular image perimeter.

2156036

13. The crop, measure and scale system of claim 10, wherein said calculating measure includes a slide rule with a slide rule ruler and an adjacent slide rule slide, said slide rule ruler defining a translator which includes a linear scale arranged to indicate the distance between opposing first and second edges and a logarithmic conversion scale aligned with said linear scale to provide for translation of said measured distance from said linear scale to said logarithmic conversion scale, and said slide rule slide including a logarithmic reduction/enlargement scale which is movable relative to said slide rule ruler to offset said logarithmic reduction/enlargement scale relative to said logarithmic conversion scale to denote a predetermined desired dimensional change of said distance.

14. The crop, measure and scale system of claim 13, wherein said slide rule further includes a reduction percentage scale and a reduction marker, one of which is fixed relative to said logarithmic conversion scale and another of which is fixed relative to said logarithmic reduction/enlargement scale, said reduction percentage scale being arranged to provide for marking by said reduction marker of a reduction percentage value corresponding to the relative offset of said logarithmic scales.

15. The crop, measure and scale system of claim 13, wherein said slide rule further includes an enlargement percentage scale and an enlargement marker, one of which is fixed relative to said logarithmic conversion scale and another of which is fixed relative to said logarithmic reduction/enlargement scale, said enlargement percentage scale being arranged to provide for marking by said enlargement marker of an enlargement percentage corresponding to the relative offset of said logarithmic scales.

16. The crop, measure and scale system of claim 10, wherein said first corner member further includes a track which extends generally parallel with one of said first edges, said second corner member being mounted for movement along said track.

17. The crop, measure and scale system of claim 16, wherein said first corner member further includes a carriage mounted for movement along said track, said carriage being configured to carry said second corner member along said track in a predetermined rotational orientation relative to said first corner member.

18. The crop, measure and scale system of claim 17, wherein said carriage defines a channel configured to receive slidably said second corner member.

19. The crop, measure and scale system of claim 10, wherein at least one of said corner members defines slots through which the original image may be marked.

2156036

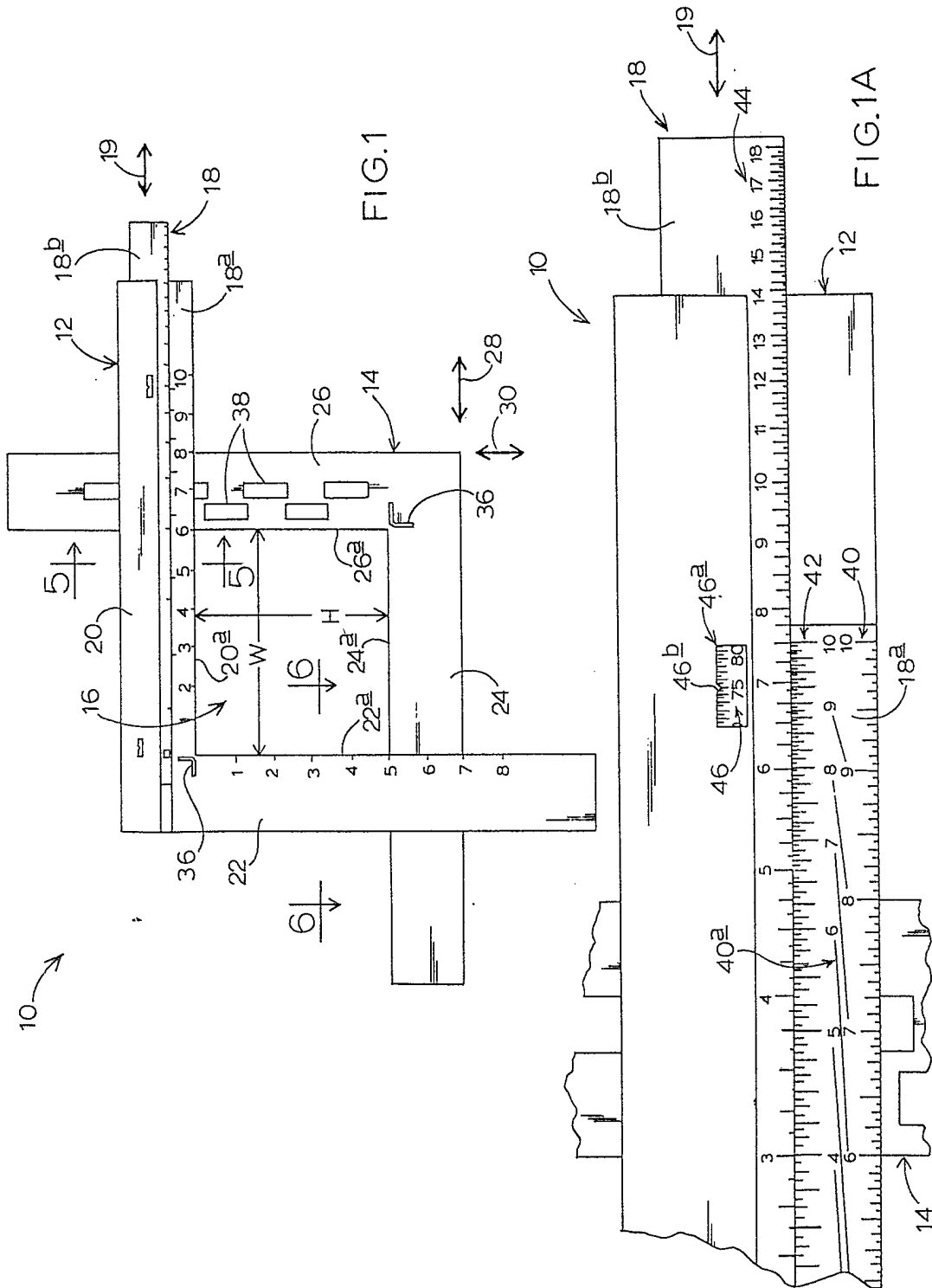
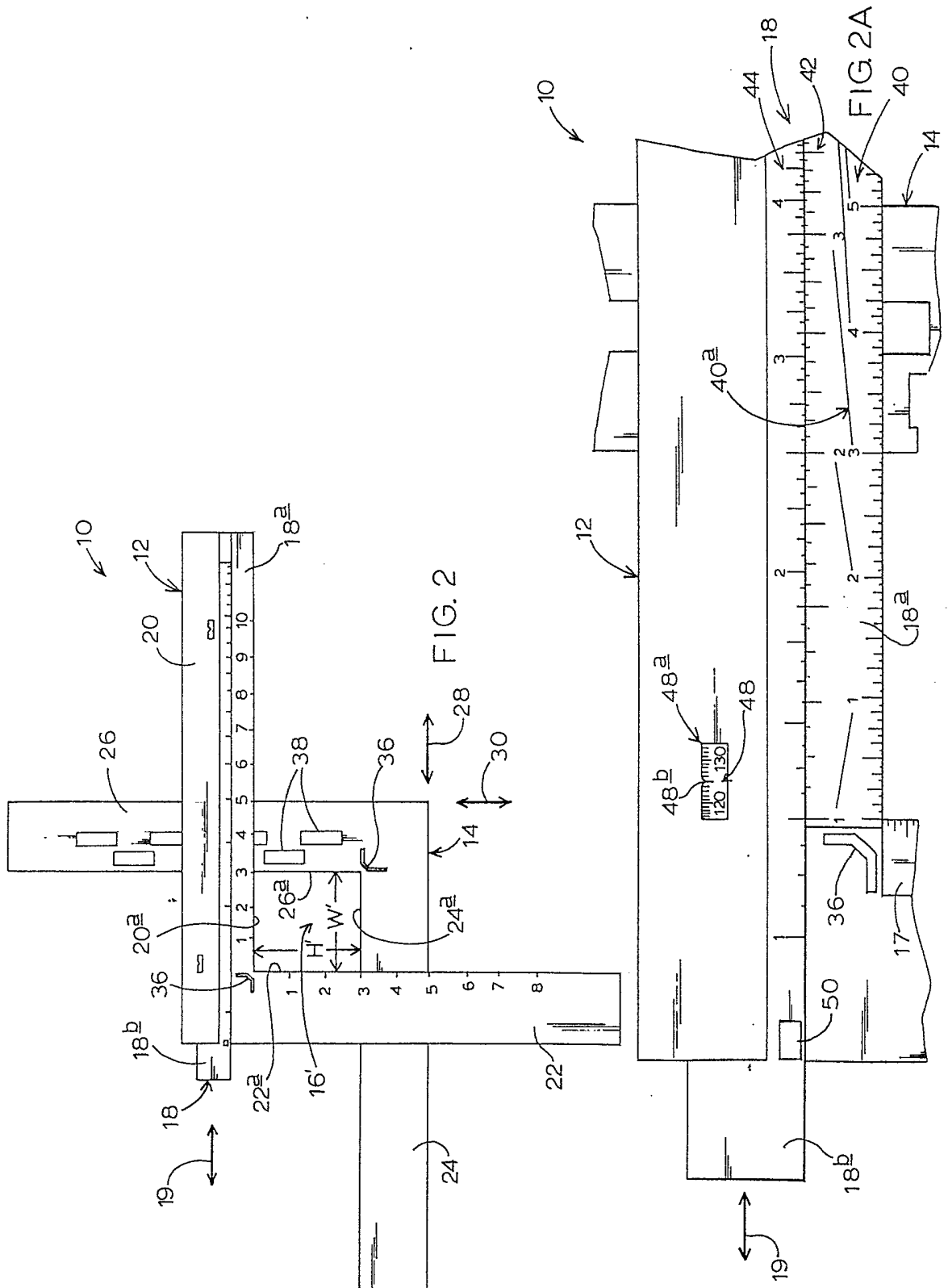

FIG. 1

FIG. 1A

Patent Agents
Fetherstonhaugh & Co.

2156036



Patent Agents
Fetherstonhaugh & Co.

2156036

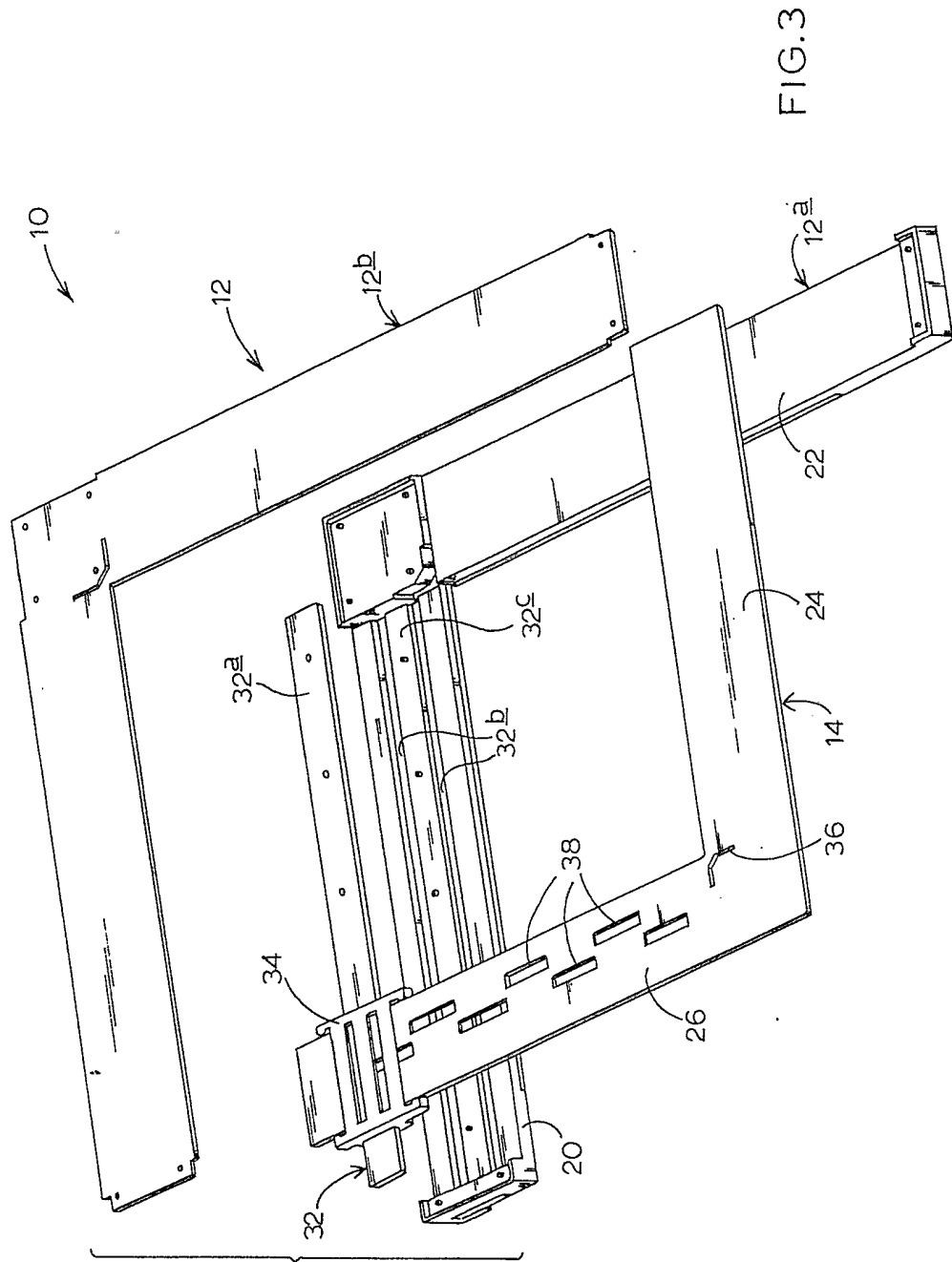

FIG. 3

Patent Agents
Fetherstonhaugh & Co.

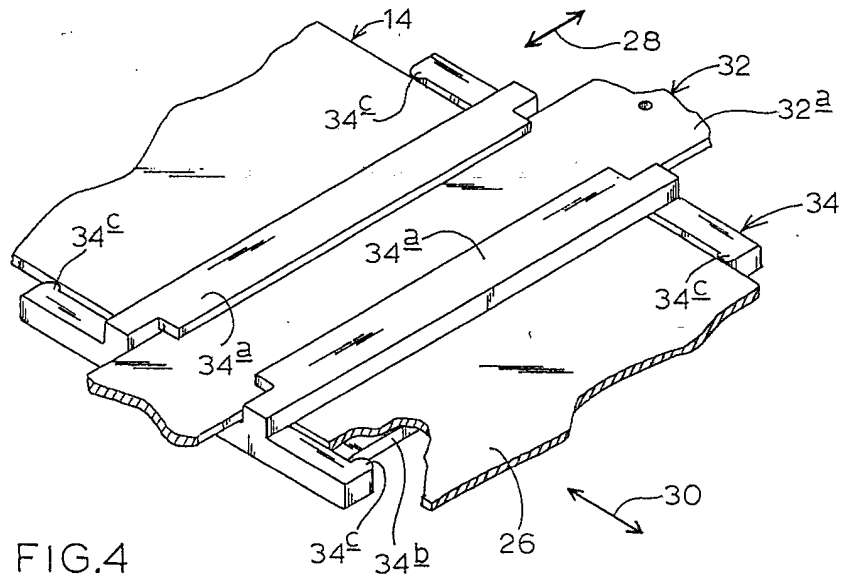

FIG. 4

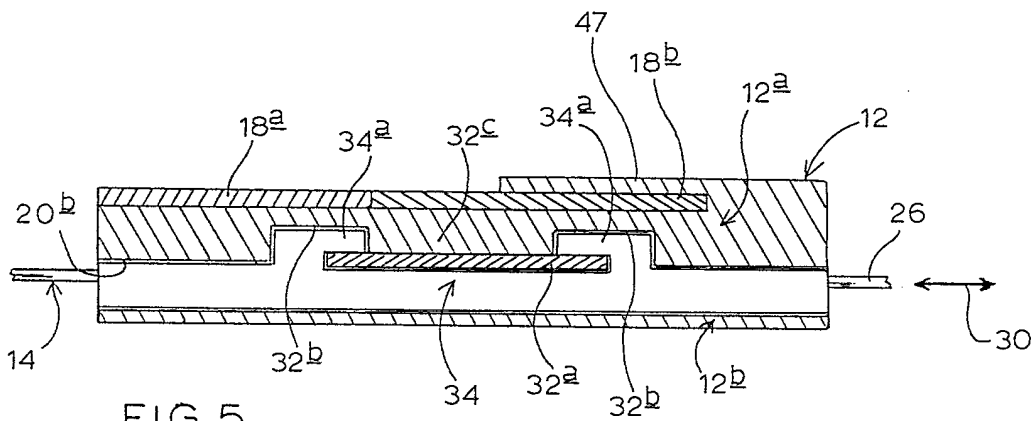

FIG. 5

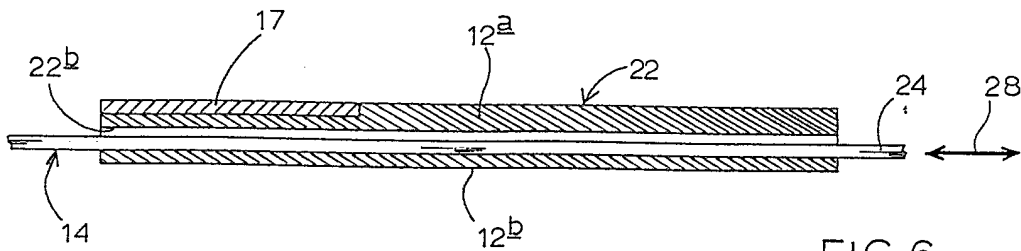

FIG. 6