

THE CONCISE STADIA COMPUTER

*Herman van Herwijnen
Memorial Edition*

THE INTERNATIONAL SLIDE RULE GROUP
SPECIAL PUBLICATION
MARCH 2005

Copyright. © 2005 by Steven C. Beadle (*scbeadle@earthlink.net*). Permission is hereby granted to the members of the International Slide Rule Group (ISRG; <http://groups.yahoo.com/group/sliderule>) and the Slide Rule Trading Group (SRTG; <http://groups.yahoo.com/group/sliderule-trade>) to make unlimited copies of this document, in either electronic or printed format, for their personal use. Commercial redistribution, without the written permission of the copyright holder, is prohibited.

Disclaimer. This document is an independently written guide for the Concise Stadia Computer, a product of the Concise Co. Ltd., located at 2-16-23, Hirai, Edogawa-ku, Tokyo, Japan (“Concise”). This guide was prepared without the authorization, consent, or cooperation of Concise. The copyright holder, and not Concise or the ISRG, is responsible for any errors or omissions.

This document was developed without translation of the Japanese language manual for the Concise Stadia Computer, or the text printed on the instrument itself, or any other documentation prepared by Concise for this instrument. Thus, there is no assurance that the guidance presented in this document accurately reflects the uses of this instrument as intended by the manufacturer, or that it offers an accurate interpretation of the scales, labels, tables, and other features of this instrument.

The interpretations presented in this document are distributed in the hope that they may be useful to English-speaking users of the Concise Stadia Computer. However, the copyright holder and the ISRG provide the document “as is” without warranty of any kind, either expressed or implied, including, but not limited to, the implied warranties of merchantability and fitness for a particular purpose. In no event will the copyright holder or the ISRG be liable to you for damages, including any general, special, incidental, or consequential damages arising out of the use or the inability to use this document.

DEDICATION

HERMAN VAN HERWIJNEN



This document was specially prepared to accompany the Herman van Herwijnen Memorial Edition of the Concise Stadia Computer – a limited edition collector's item commissioned by the International Slide Rule Group to mark Herman's contributions to the slide rule collecting community.

Herman first started using a slide rule when studying for his master's degree in Mechanical Engineering at the Technische Hogeschool (TH) in Delft. After rediscovering his old slide rule decades later, Herman became a founding member of the Dutch slide rule society – “De Kring”. Soon his own collection and depth of knowledge on slide rules was second to none – as all members of the International Slide Rule Group will know. But perhaps Herman's greatest legacy is the “Slide Rule Catalogue”.

Early versions of the catalogue were paper based and in Dutch. But by the mid-nineties, growing international interest meant a change to English and a move to an electronic catalogue. Herman died on Sunday, August 8th 2004, at age 74, but his legacy is much more than a CD/DVD holding the details of 5500 slide rules – 3300 of them with high-resolution pictures. Herman pioneered the cataloguing of slide rules and devised many associated standards that have now been adopted worldwide – making this commemorative slide rule a fitting tribute.

CONTENTS

Copyright	i
Disclaimer	i
Dedication: Herman van Herwijnen	ii

CHAPTER 1

INTRODUCTION

PART	PAGE
1. Stadia Rules	1
2. The Concise Stadia Computer	1
3. Ordering Information	2
4. The International Slide Rule Group	2
5. Herman van Herwijnen Memorial Edition	2

CHAPTER 2

SLOPE MEASUREMENT CONVERSIONS

6. Definitions	3
7. General Conversion Method	3
8. Slope Angle vs. Grade	5

CHAPTER 3

SLOPE DISTANCE CALCULATIONS

9. Measured Slope Angle and Slope Distance	7
10. Measured Grade and Slope Distance	9
11. Two Measured Grades and Rod Distance	10

CONTENTS (continued)

CHAPTER 4

STADIA DISTANCE CALCULATIONS

PART	PAGE
12. Principles of Stadia Surveying	12
13. Stadia Surveying Calculations	14
14. General Corrections for Exterior Focusing Instruments	15
15. Corrections for Exterior Focusing Instruments if C = 1 Foot	17

TABLES

No.	PAGE
1. General Slope Measurement Conversions	4
2. Slope Angle vs. Percent Grade Conversions	5
3. Supplemental Horizontal and Vertical Corrections for Exterior-Focusing Telescopes, in Feet	16

FIGURES

1. Slope Measurement Definitions	3
2. Slope Angle and Slope Distance Measurement	7
3. Multiple Percent Grade and Rod Distance Measurements	10
4. Stadia Rod as Viewed by Telescope	12
5. Stadia Surveying on a Flat Surface	13
6. Stadia Surveying on a Slope	13
7. Stadia Surveying with an Exterior Focusing Telescope	15
8. Supplemental Slope Components for an Exterior-Focusing Telescope	16

CHAPTER 1

INTRODUCTION

1. Stadia Rules. Slide rules for stadia survey calculations were apparently developed during the late 19th Century. They were widely used throughout most of the 20th Century, and were distributed by a number of Japanese, American, and European slide rule manufacturers. However, both slide rules and the stadia surveying technique itself were largely abandoned during the late 20th Century. Today, distances are typically surveyed using electronic distance measurement equipment or global positioning systems.

2. The Concise Stadia Computer. Stadia rules are still valued by collectors of slide rules or traditional surveying instruments. The Concise Stadia Computer, manufactured by the Concise Co. Ltd., of Tokyo, Japan, is of particular interest to collectors, since it is probably the last stadia rule in commercial production today. It also has several unusual features not found on other stadia rules. These features are not always fully understood, however, because the instrument is not supplied with English language documentation.

This unofficial guide has been prepared in the hope that it may be helpful to English-speaking users of the Concise Stadia Computer. Such users should, however, first review the important limitations outlined above in the Disclaimer.

The Concise Stadia Computer is a circular duplex slide rule measuring about 3 ³/₄ inches (or 9.6 cm) in diameter. Because of its circular design, it fits within a shirt pocket, yet its outer scales are comparable in length and accuracy to the scales on a straight 10 inch (or 25 cm) slide rule.

The Concise Stadia Computer can be used to address a variety of problems involving multiplication, division, reciprocals, and trigonometric functions. This guide focuses

on its use for problems involving surveyed slopes, including slope measurement conversions (Chapter 2), slope distance calculations (Chapter 3), and stadia distance calculations (Chapter 4).

The front side of the instrument may be identified by the prominent “Concise Stadia Computer” label. The front side includes several scales for stadia distance calculations; it also features a lookup table for correcting distance measurements obtained with older instruments (Chapter 4). The reverse side of the instrument includes several trigonometric scales, which may be used for slope measurement conversions and slope distance calculations; it also features specialized scales for use with percent grade measurements (Chapters 2 and 3).

3. Ordering Information. Customers outside Japan may order the Concise Stadia Computer from the Concise Online Shop on the Internet. The retail price for this product in March 2005 was ¥2,000 (about US\$20 or €15), exclusive of tax and shipping. After the online order form is submitted, a Concise representative will provide a full cost estimate by e-mail. Credit cards are accepted.

A catalog of all “function-minded quality products” available from Concise is currently online at http://www.concise.co.jp/eng0731/top_eng.html. Descriptions of all Concise circular slide rules, including the Concise Stadia Computer, are posted online at <http://www.concise.co.jp/eng0731/circle01.html>.

4. The International Slide Rule Group. The International Slide Rule Group (ISRG) is an online forum devoted to collectors of slide rules and associated mechanical calculating instruments. The ISRG was founded in 1998, and had over 1,000 members in 2005; its address is <http://groups.yahoo.com/group/sliderule>. The Slide Rule Trading Group (SRTG) offers private buying, selling and trading for members of the ISRG, and is located at <http://groups.yahoo.com/group/sliderule-trade>.

5. Herman van Herwijnen Memorial Edition. In 2004, the ISRG commissioned a commemorative edition of the Concise Stadia Computer, in memory of Herman van Herwijnen. This edition is specially engraved on the front side, and comes with a customized slipcase. The production run was limited to approximately 150 pieces.

CHAPTER 2

SLOPE MEASUREMENT CONVERSIONS

6. **Definitions.** The steepness of a measured slope may be expressed in terms of slope angle, percent grade, or slope ratio. These slope measurements are defined as follows:

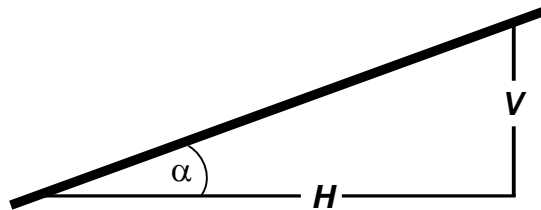

Figure 1. Slope Measurement Definitions

$$\text{Slope Angle } (\alpha) = \arctan \left(\frac{V}{H} \right) = \arctan \left(\frac{\%g}{100} \right) \quad (\text{Eq. 1})$$

$$\text{Percent Grade } (\%g) = 100 \left(\frac{V}{H} \right) = 100 \tan \alpha \quad (\text{Eq. 2})$$

$$\text{Slope Ratio} = \left(\frac{H}{V} \right) : 1 = \left(\frac{1}{\tan \alpha} \right) : 1 = \left(\frac{100}{\%g} \right) : 1 \quad (\text{Eq. 3})$$

For example, a slope angle of 14° is nearly equivalent to a 25 % grade, or a slope ratio of 4 : 1. The Concise Stadia Computer can be used to make conversions between these different forms of slope measurement.

7. **General Conversion Method.** By using both sides of the instrument, the slope angle, slope ratio, and percent grade can be evaluated simultaneously. For clarity, the D-scale on the front side of the Concise Stadia Computer will be described here as the “DI-scale,” to distinguish it from the D-scale on the reverse side.

To use the general conversion method, the C- and D-scales on the reverse side of the instrument must be aligned. If the cursor is set to the slope angle on the black-labeled

ST-, T1-, or T2-scale, then the equivalent percent grade will be marked on the C/D-scales; the corresponding slope ratio will be marked on the DI-scale on the front side. The decimal point must be set carefully for percent grade and slope ratio, in accordance with Table 1 below.

Table 1. General Slope Measurement Conversions

Percent Grade			Slope Angle				Slope Ratio		
Min	Max	Scale	Scale	Min	Max	Scale	Scale	Min	Max
1.16	10.5	C/D	ST	40'	6°	ST	DI	86 : 1	9.51 : 1
10.5	100	C/D	T1	6°	45°	T1	DI	9.51 : 1	1 : 1
100	951	C/D	T2	45°	84°	T2	DI	1 : 1	0.105 : 1

Example: Determine the slope angles and slope ratios equal to 2 %, 20 %, and 200 % grades.

Solution: Align the C- and D-scales. Set the cursor to 2 on the C/D-scales.

Read slope angles of: 1° 9' on the ST-scale;
11° 19' on the T1-scale;
63° 25' on the T2-scale.

Read slope ratios of: 50:1;
5:1;
0.5:1 on the DI-scale on the front side.

Example: Convert slope angles of 45', 7° 30', and 75° to percent grade and slope ratio.

Solution: Align the C- and D-scales.

Set the cursor to 45' on the ST-scale:
read grade of 1.31 % on the C/D-scales;
read slope ratio of 76.5 : 1 on the DI-scale.

Set the cursor to 7° 30' on the T1-scale:
read grade of 13.2 % on the C/D-scales;
read slope ratio of 7.6 : 1 on the DI-scale.

Set the cursor to 75° on the T2-scale:
read grade of 373 % on the C/D-scales;
read slope ratio of 0.268 : 1 on the DI-scale.

Example: Determine the slope angles and grades corresponding to slope ratios of 46:1, 4.6:1, and 0.46:1.

Solution: Set the cursor to 4.6 on the DI-scale on the front side.

Align the C- and D-scales on the reverse side.

Read grades of: 2.17 %;
21.7 %;
217 % on the C/D-scales.

Read slope angles of: 1° 15' on the ST-scale;
12° 16' on the T1-scale;
65° 18' on the T2-scale.

8. Slope Angle vs. Grade. The Concise Stadia Computer supports an additional method for conversions between slope angle and percent grade. This alternative approach uses the C-scale and the black-labeled C'-scale, together with the ST- and S-scales, as per Table 2 below.

Table 2. Slope Angle vs. Percent Grade Conversions

<i>Slope Angle</i>			<i>Percent Grade</i>		
<i>Minimum</i>	<i>Maximum</i>	<i>Scale</i>	<i>Scale</i>	<i>Minimum</i>	<i>Maximum</i>
40'	5° 43'	ST	C	1.16	10
5° 43'	36° 52'	ST/S	C'	10	75

The advantage to this method is that the percent grade can be read directly from the C- or C'-scales, without any need to set the decimal point. A disadvantage is it cannot be used to determine slope ratios. Another drawback is that it cannot be used for measured slopes steeper than 75 % grade (or nearly 37°), although such steep slope measurements are comparatively rare in practice. In such cases, the general conversion method described previously may be used instead.

Example: Determine the slope angles equivalent to 1.8 % and 18 % grades.

Solution: Set the cursor to 1.8 on the C-scale.

Read slope angle of 1° 2' on the ST-scale.

Set the cursor to 18 on the C'-scale.

Read slope angle of 10° 12' on the S-scale.

Example: Determine the percent grades corresponding to slope angles of 3° and 30°.

Solution: Set the cursor to 3° on the ST-scale.

Read 5.24 % grade on the C-scale.

Set the cursor to 30° on the S-scale.

Read 57.7 % grade on the C'-scale.

CHAPTER 3

SLOPE DISTANCE CALCULATIONS

9. Measured Slope Angle and Slope Distance. A transit or alidade may be used to measure the slope angle (α) at a given location (Figure 2). Ideally, the transit should be aimed at a stadia rod target set at the same height above grade as the instrument itself; in other words, the height of the instrument (V_i) should equal the height of the rod target (V_r). The slope distance (L) between the base of the transit and the base of the rod may be measured by taping or chaining.

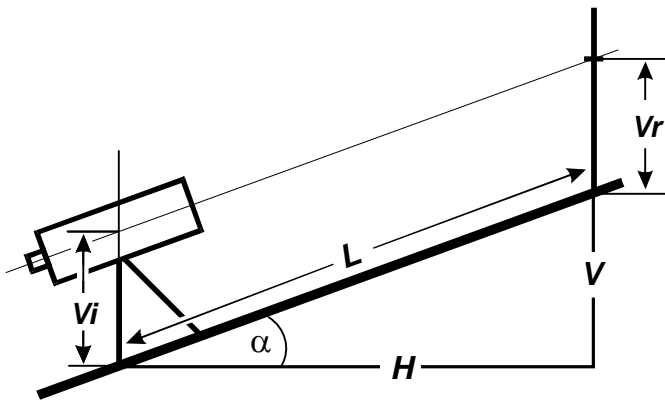

Figure 2. Slope Angle and Slope Distance Measurement

If the values of α and L are measured, then the horizontal (H) and vertical (V) distances between the transit and the rod target may be determined in accordance with Equations 4 to 7:

$$\text{If } V_i = V_r, \text{ then: } V = L \sin \alpha \quad (\text{Eq. 4})$$

$$\text{If } V_i \neq V_r, \text{ then: } V' = V + V_i - V_r \quad (\text{Eq. 5})$$

$$\text{If } \alpha > 6^\circ, \text{ then } H = L \cos \alpha \quad (\text{Eq. 6})$$

$$\text{If } \alpha < 6^\circ, \text{ then } H \approx L \quad (\text{Eq. 7})$$

These equations may be solved using the C-, D-, S-, and ST-scales on the reverse side of the Concise Stadia Computer. For calculating V , the black labels on the S- and ST-scales are used (since the black labels are used to determine sines). For calculating H , the red labels on the S- and ST-scales are used (since the red labels are used to determine cosines). For clarity, the S- and ST-scales will be described as the “rS-” and “rST-scales” when the red labels are used. The black arrow surrounding the “1” label on the C-scale is here termed the “C-index.”

To calculate V , align the C-index with L on the D-scale. Set the cursor on α using the ST-scale (if $\alpha \leq 6^\circ$) or the S-scale (if $\alpha \geq 6^\circ$). The cursor will then mark V on the D-scale, as per Equation 4. The decimal point must be set as appropriate. If $V_i \neq V_r$ (Figure 2), then the calculated value for V must be corrected to V' , in accordance with Equation 5.

To calculate H , keep the alignment of the C- and D-scales. Move the cursor to α on the rS-scale (the rST-scale may be used in the unlikely event that $\alpha \geq 84^\circ$). The cursor will then mark H on the D-scale, as per Equation 6. If $\alpha \leq 6^\circ$, then for most practical purposes it may be assumed that $H = L$, as per Equation 7.

Example: Calculate V and H , given measured $\alpha = 11^\circ 48'$ and $L = 117$ feet.

Solution: Set the C-index below 1.17 on the D-scale.

Set the cursor to $11^\circ 48'$ on the S-scale,
read V of 23.9 feet on the D-scale.

Set the cursor to $11^\circ 48'$ on the rS-scale,
read H of 114.5 feet on the D-scale.

Example: Calculate V and H , given measured $\alpha = 2^\circ 21'$ and $L = 216$ feet.

Solution: Set the C-index below 2.16 on the D-scale.

Set the cursor to $2^\circ 21'$ on the ST-scale,
read V of 8.86 feet on the D-scale.

Since $\alpha < 6^\circ$, it may be assumed that $H = L$. To verify this,
set the cursor to $2^\circ 21'$ on the rS-scale,
read H of 216 feet on the D-scale.

10. Measured Grade and Slope Distance. Some transits and alidades express vertical inclination in terms of percent grade (%g), rather than as a slope angle. If measured values for %g and L are available, then the corresponding values for V and H may be calculated using equations 8 to 11:

$$\text{By Eqns. 1 and 4: } V = L \sin \left[\arctan \left(\frac{\%g}{100} \right) \right] \quad (\text{Eq. 8})$$

$$\text{If } \%g < 10, \text{ then: } V \approx \left(\frac{\%g}{100} \right) L \quad (\text{Eq. 9})$$

$$\text{By Eqns. 1 and 6: } H = L \cos \left[\arctan \left(\frac{\%g}{100} \right) \right] \quad (\text{Eq. 10})$$

$$\text{If } \%g < 10, \text{ then } H \approx L \quad (\text{Eq. 11})$$

These equations may be solved using the C-, C'-, and D-scales on the reverse side of the Concise Stadia Computer. The black-labeled C'-scale is specifically designed to solve Equation 8 for $10 < \%g \leq 75$. The red-labeled C'-scale (here termed the "rC'-scale") is designed to solve Equation 10 for $10 < \%g \leq 75$.

To calculate V, align the C-index with L on the D-scale. Set the cursor on %g using the C-scale (if $\%g \leq 10\%$) or the C'-scale (if $\%g > 10\%$). The cursor will then mark V on the D-scale, in accordance with Equations 8 and 9. The decimal point must be set as appropriate. If $V_i \neq V_r$, then the calculated value for V must be corrected to V' , as per Equation 5.

To calculate H, keep the alignment of the C- and D-scales. Move the cursor to %g on the rC'-scale. The cursor will then mark H on the D-scale, as per Equation 10. If $\%g < 10\%$, then for most practical purposes it may be assumed that $H = L$, as per Equation 11.

Example: Calculate H and V, given a measured 15.2 % grade and L = 288 feet.

Solution: Set the C-index below 2.88 on the D-scale.

Set the cursor to 15.2 on the C'-scale,

read V of 43.3 feet on the D-scale.

Set the cursor to 15.2 on the rC'-scale,

read H of 285 feet on the D-scale.

Example: Calculate V and H, given a measured 1.25 % grade and L = 406 feet.

Solution: Set the C-index below 4.06 on the D-scale.

Set the cursor to 1.25 on the C-scale,

read V of 5.08 feet on the D-scale.

Since $\%g \leq 10\%$, it may be assumed that $H = L$. To verify this,

set the cursor to 1.25 on the rC'-scale,

read H of 406 feet on the D-scale.

11. Two Measured Grades and Rod Distance. It is also possible to determine V and H without measuring the slope distance L. An initial grade measurement (%g1) is obtained using a rod target set at height Vr1 (ideally $Vr1 = V_i$). A second grade measurement (%g2) is then obtained after raising the rod target to height Vr2 (Figure 3). In this case, V and H may then be calculated using Equations 12 to 15.

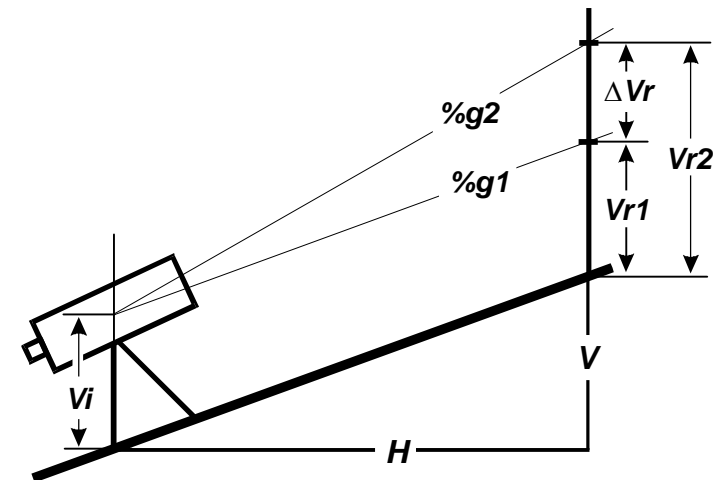

Figure 3. Multiple Percent Grade and Rod Distance Measurements

$$\Delta V_r = V_{r2} - V_{r1} \quad (\text{Eq. 12})$$

$$\Delta \%g = \%g2 - \%g1 \quad (\text{Eq. 13})$$

$$H = \Delta V_r \left(\frac{100}{\Delta \%g} \right) \quad (\text{Eq. 14})$$

$$V = H \left(\frac{\%g1}{100} \right) \quad (\text{Eq. 14})$$

To calculate H, it is first necessary to determine ΔV_r and $\Delta\%g$. Then set the cursor to ΔV_r on the D-scale, and align $\Delta\%g$ on the C-scale to the cursor as well. The C-index will then mark H on the D-scale. The decimal point must be set as appropriate.

To calculate V, keep the alignment of the C- and D- scales, but move the cursor to $\%g_1$ on the C-scale. The cursor will then mark V on the D-scale. The decimal point must be set as appropriate. If $V_i \neq V_r$, the calculated value for V should be corrected to V' , in accordance with Equation 5.

Example: Calculate H and V, given $\%g_1 = 1.71\%$, $V_{r1} = 3.00$ feet, $\%g_2 = 2.53\%$, and $V_{r2} = 5.00$ feet.

Solution: Determine $\Delta V_r = (V_{r2} - V_{r1}) = (5.00 - 3.00 \text{ feet}) = 2.00$ feet

Determine $\Delta\%g = (\%g_2 - \%g_1) = (2.53 - 1.71) = 0.82$

Set the cursor to 2 on the D-scale,

align 8.2 on the C-scale to the cursor,

read H of 243.9 feet above the C-index on the D-scale.

Set the cursor to 1.71 on the C-scale,

read V of 4.17 feet on the D-scale.

Example: Calculate H and V, given $\%g_1 = 5.2\%$, $V_{r1} = 3.20$ feet, $\%g_2 = 9.6\%$, and $V_{r2} = 7.20$ feet.

Solution: Determine $\Delta V_r = (V_{r2} - V_{r1}) = (7.20 - 3.20 \text{ feet}) = 4.00$ feet

Determine $\Delta\%g = (\%g_2 - \%g_1) = (9.6 - 5.2) = 4.4$

Set the cursor to 4 on the D-scale,

align 4.4 on the C-scale to the cursor,

read H of 90.9 feet above the C-index on the D-scale.

Set the cursor to 5.2 on the C-scale,

read V of 4.73 feet on the D-scale.

CHAPTER 4

STADIA DISTANCE CALCULATIONS

12. Principles of Stadia Surveying. In stadia surveying, distances are measured indirectly, by measuring the apparent size of a distant stadia rod. This technique is much faster than direct distance measurements by taping or chaining (although it is generally not as accurate).

For stadia surveying, the telescope of the transit or alidade is equipped with two horizontal lines, known as the “stadia hairs,” which are located at equal heights above and below the centerline. A graduated stadia rod is viewed at a distance through the telescope, and the visible length of the stadia rod between the stadia hairs is measured (Figure 4).

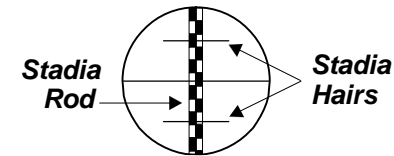

Figure 4. Stadia Rod as Viewed by Telescope

In the simplest case, the survey is conducted on a flat surface (Figure 5). The telescope is aimed at a rod target set at the same height above grade as the instrument itself, such that $V_i = V_r$. Most modern telescopes are internal-focusing, so that the focusing point coincides with the center of the instrument. In this case, the distance between the instrument and the rod (L) is directly proportional to the visible stadia interval (s), as per Equation 15. The constant of proportionality is known as the “stadia factor” (K). Most instruments are designed so that $K = 100$.

$$L = Ks \quad (\text{typically } K = 100, \text{ so } L = 100s) \quad (\text{Eq. 15})$$

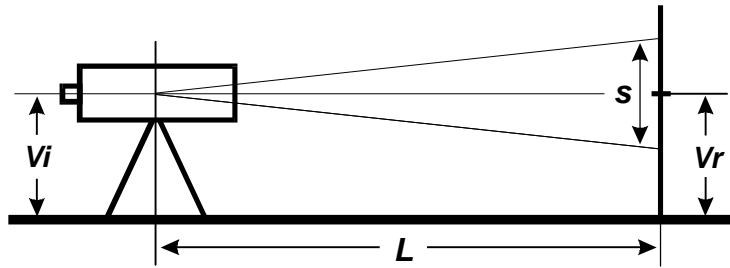

Figure 5. Stadia Surveying on a Flat Surface

Stadia calculations are more complex on slopes (Figure 6). Since the stadia rod is held vertically, it is viewed at an angle when set on a slope. The apparent stadia interval (s) must be corrected to the value that would be obtained if the rod was held normal to the line of sight; the corrected stadia interval (s') is closely approximated by Equation 16. The corrected stadia interval may then be used to determine the slope distance (L), based on Equation 17. The vertical (V) and horizontal (H) components of the slope may be calculated in accordance with Equations 18 and 19.

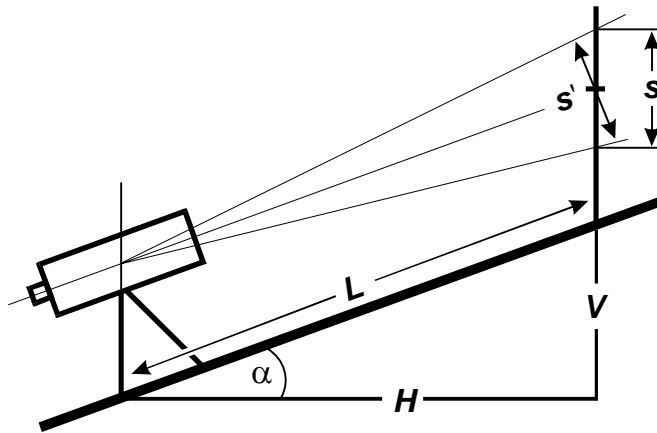

Figure 6. Stadia Surveying on a Slope

$$s' \approx s \cos \alpha \quad (\text{Eq. 16})$$

$$\text{from Eq. 15:} \quad L = Ks' \quad (\text{Eq. 17})$$

$$\text{from Eqs. 4 and 17:} \quad V = Ks' \sin \alpha \quad (\text{Eq. 18})$$

$$\text{from Eqs. 6 and 17:} \quad H = Ks' \cos \alpha \quad (\text{Eq. 19})$$

Assuming that $K = 100$, Equations 20 and 21 may be derived. These are the fundamental equations used to calculate stadia distances. If $V_i \neq V_r$, the calculated value for V should be corrected to V' , in accordance with Equation 5.

$$\text{from Eqs. 16 and 18:} \quad V = 100s \sin \alpha \cos \alpha \quad (\text{Eq. 20})$$

$$\text{from Eqs. 16 and 19:} \quad H = 100s \cos^2 \alpha \quad (\text{Eq. 21})$$

13. Stadia Survey Calculations. Stadia distance calculations are conducted using the scales on the front side of the Concise Stadia Computer. The black scales, labeled “SIN COS”, are used to determine V , in accordance with Equation 20. There are three SIN COS-scales: an inner scale running from 4' to 40', a middle scale running from 40' to 6°, and an outer scale running from 6° to 40°. The red scale, labeled “COS²,” is used to determine H , in accordance with Equation 21. The COS²-scale runs from 0° to 45°, and is associated with the outer SIN COS-scale. The red arrow surrounding the “0” label on the COS² scale is here termed the “0-index”.

A stadia survey measurement should include the slope angle (α) and the visible stadia interval (s). To compute V , align the 0-index with s on the D-scale. Set the cursor to α on the inner, middle, or outer SIN COS-scale. The cursor will then mark V on the D-scale. The decimal point must be set as appropriate, including multiplication by 100 as per Equation 20. If $V_i \neq V_r$, then V must be corrected as per Equation 5.

To compute H , leave the 0-index aligned with s on the D-scale. Move the cursor to α on the COS²-scale. The cursor will then mark H on the D-scale. The decimal point must be set as appropriate, including multiplication by 100 as per Equation 21. Note that $H \approx 100s$ for $\alpha < 5^\circ$.

Example: Calculate V and H , given $\alpha = 3^\circ 40'$ and $s = 2.3$ feet.

Solution: Align the 0-index with 2.3 on the D-scale.

Set the cursor to $3^\circ 40'$ on the middle SIN COS-scale,

read V of 14.7 feet on the C-scale.

Set the cursor to $3^\circ 40'$ on the COS²-scale,

read H of 229 feet on the C-scale.

Example: Calculate V and H, given $\alpha = 12^\circ 30'$ and $s = 3.1$ feet.

Solution: Align the 0-index with 3.1 on the D-scale.

Set the cursor to $12^\circ 30'$ on the outer SIN COS-scale,

read V of 65.5 feet on the C-scale.

Set the cursor to $12^\circ 30'$ on the COS^2 -scale,

read H of 295 feet on the C-scale.

14. General Corrections for Exterior-Focusing Instruments. On older instruments, the focusing point of the telescope may be exterior rather than internal (Figure 7). In such cases, the focusing point is some distance in front of the instrument, rather than at the center. If the objective lens at the front of the telescope moves in and out as the focus is adjusted, then the telescope is externally focused.

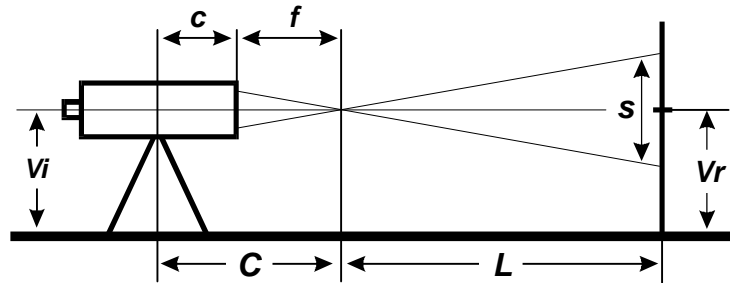

Figure 7. Stadia Surveying with an Exterior-Focusing Telescope

On exterior-focusing telescopes, the distance between the center and front of the telescope (c) plus the focal length of the objective lens (f) must be added to the measured distance to the stadia rod (L). The distance ($f + c$) is known as the “stadia constant” (C). Typically C is about 1 foot (or 0.3 meters).

For stadia measurements on slopes, the supplemental vertical (V_2) and horizontal (H_2) components of C must be added to the calculated vertical (V) and horizontal (H) distances (Figure 8). The values of V_2 and H_2 may be calculated as per Equations 22 and 23, using the procedures outlined in Part 7 of Chapter 2. The supplemental V_2 and H_2 values are added to V and H to obtain the total vertical (V_t) and horizontal (H_t) distances, as per Equations 24 and 25. If $V_i \neq V_r$, the calculated value for V_t should be corrected to V_t' , in accordance with Equation 5.

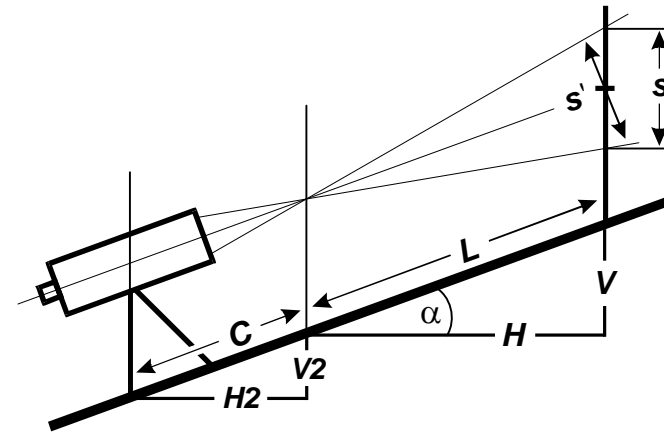

Figure 8. Supplemental Slope Components for an Exterior-Focusing Telescope

from Eq. 4: $V_2 = C \sin \alpha$ (Eq. 22)

from Eq. 6: $H_2 = C \cos \alpha$ (Eq. 23)

$V_t = V + V_2$ (Eq. 24)

$H_t = H + H_2$ (Eq. 25)

Alternatively, the values of H_2 and V_2 may be quickly estimated using a lookup table. A metric lookup table, listing H_2 and V_2 in meters for various values of C and α , is included on the front side of the Concise Stadia Computer. A comparable lookup table, listing H_2 and V_2 in feet, is included below as Table 3. The values of H_2 and V_2 for unlisted values of α can be estimated by interpolation.

Table 3. Supplemental Horizontal (H_2) and Vertical (V_2) Corrections for Exterior-Focusing Telescopes, in Feet

C	5°		10°		15°		20°		25°		30°	
	H2	V2	H2	V2	H2	V2	H2	V2	H2	V2	H2	V2
0.75 ft	0.75	0.07	0.74	0.13	0.72	0.19	0.70	0.26	0.68	0.32	0.65	0.38
1.00 ft	1.00	0.09	0.98	0.17	0.97	0.26	0.94	0.34	0.91	0.42	0.87	0.50
1.25 ft	1.25	0.11	1.23	0.22	1.21	0.32	1.17	0.43	1.13	0.53	1.08	0.63

Example: Calculate V_t and H_t for an exterior-focusing instrument, given that

$\alpha = 6^\circ 15'$, $s = 1.25$ feet, and $C = 1$ foot.

Solution: To calculate V and H , use the front side of the Concise Stadia Computer.

Align the 0-index with 1.25 on the D-scale.

Set the cursor to $6^\circ 15'$ on the outer SIN COS-scale,

read V of 13.5 feet on the C-scale.

Set the cursor to $6^\circ 15'$ on the COS^2 -scale,

read H of 123.5 feet on the C-scale.

To calculate V_2 and H_2 , use the reverse side of the Concise Stadia Computer.

Align the C-index with 1 on the D-scale.

Set the cursor to $6^\circ 15'$ on the S-scale,

read V_2 of 0.109 feet on the D-scale.

Set the cursor to $6^\circ 15'$ on the rS-scale,

read H_2 of 0.995 feet on the C-scale.

Alternatively, to quickly estimate V_2 and H_2 , use Table 3.

For $C = 1$ foot, H_2 is between 1.00 (for $\alpha = 5^\circ$) and 0.98 (for $\alpha = 10^\circ$),

estimate H_2 at approximately 0.995 for $\alpha = 6^\circ 15'$.

For $C = 1$ foot, V_2 is between 0.09 (for $\alpha = 5^\circ$) and 0.17 (for $\alpha = 10^\circ$),

estimate V_2 at approximately 0.11 for $\alpha = 6^\circ 15'$.

$V_t = V + V_2 = 13.5 \text{ feet} + 0.11 \text{ feet} = 13.6 \text{ feet}$

$H_t = H + H_2 = 123.5 \text{ feet} + 0.995 \text{ feet} = 124.5 \text{ feet}$

15. Corrections for Exterior-Focusing Instruments if $C = 1$ Foot. Exterior-focusing instruments, particularly in the United States, were often designed so that $C = 1$ foot exactly. Thus, the distance between the center of the telescope and the rod in feet (Figures 7 and 8) is $(L + C) = (L + 1)$. For practical purposes, this distance can be closely approximated by Equation 26; thus V_t and H_t are closely approximated by Equations 27 and 28. If $C = 1$ foot, this approach determines V_t and H_t directly, without the need to calculate the supplementary V_2 and H_2 corrections.

$$\text{from Eqs. 16 and 17: } L + 1 \approx K \cos \alpha (s + 0.01) \quad (\text{Eq. 26})$$

$$\text{from Eqs. 20 and 26: } V_t \approx 100 (s + 0.01) \sin \alpha \cos \alpha \quad (\text{Eq. 27})$$

$$\text{from Eqs. 21 and 26: } H_t \approx 100 (s + 0.01) \cos^2 \alpha \quad (\text{Eq. 28})$$

To compute V_t and H_t by this approach, use the procedures outlined in Part 11. However, the C-index should be set on $(s + 0.01)$, rather than s .

Example: Calculate V_t and H_t for an exterior-focusing instrument, given that

$\alpha = 6^\circ 15'$, $s = 1.25$ feet, and $C = 1$ foot. This is the same example presented previously in Part 12.

Solution: To calculate V_t and H_t , use the front side of the Concise Stadia Computer.

Determine $(s + 0.01) = (1.25 + 0.01) = 1.26$

Align the 0-index with 1.26 on the D-scale.

Set the cursor to $6^\circ 15'$ on the outer SIN COS-scale,

read V_t of 13.6 feet on the C-scale.

Set the cursor to $6^\circ 15'$ on the COS^2 -scale,

read H_t of 124.5 feet on the C-scale.

Note that V_t and H_t obtained in this manner are identical with the values obtained in Part 12.